

## FITTING INSTRUCTION

Clamp mark in acc. with		Cables joining
ISO	PN	
1	L	Left directional lights
2	+	Rear fog lights
3	31	Ground
4	R	Right directional lights
5	58R	Right side parking lights
6	54	Stoptlights
7	58L	Left side parking lights

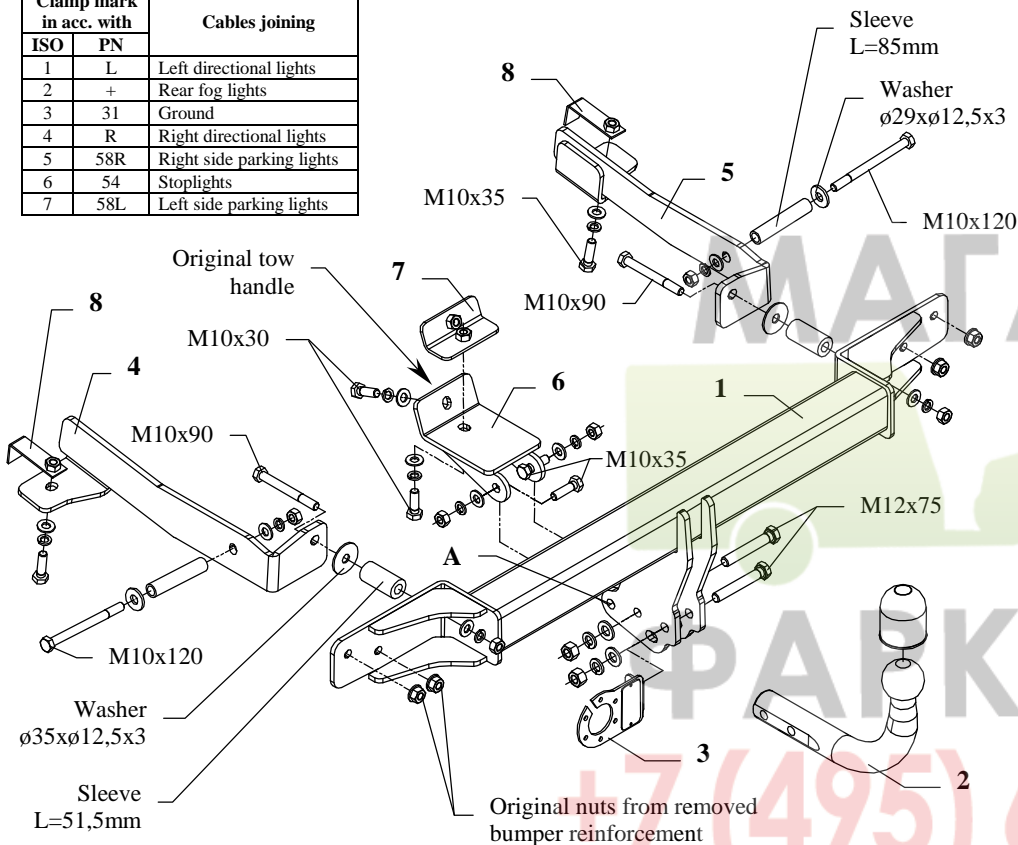

This towing hitch is designed to assembly in following cars:  
**HONDA ACCORD TOURER/WAGON Estate**, produced since 12.2002 till 2008, catalogue no. **Y28** and is prepared to tow trailers max total weight **1500 kg** and max vertical load **75 kg**.

### From manufacturer

Thank you for buying our product. Their reliability has been confirmed in many tests. Reliability of towing hitch depends also on correct assembly and right operation. For this reasons we kindly ask to read carefully this instruction and apply to hints.

*The towing hitch should be install in points described by a car producer.*

## The instruction of the assembly

1. Disassemble the bumper and metal reinforcement (not used any more).
2. In the figure no. 1 and 2 shown points to drill holes  $\phi 11$ mm.
3. To the left and right chassis member slip sleeve  $L=85$ mm (pos. 10), see fig.
4. To drilled holes put sleeves  $L=51,5$ mm (pos. 9).
5. To the inside of chassis members and rear part of the car put brackets (pos. 4 and 5) and fix using bolts  $M10 \times 120$ mm (pos. 12) through sleeves and bolts  $M10 \times 35$ mm (pos. 14) through nuts on the jib (pos. 8).
6. Put the main bar of the towing hitch (pos. 1) on protruding elements (bolts) of removed metal reinforcement and fix using original nuts  $M8$  (from reinforcement) and using  $M10 \times 90$ mm (pos. 13) - see fig.
7. Elements of the towing hitch (pos. 6 and 7) fix loosely to the original tow handle, and next through holes (pos. A) of ball brackets fix using bolts  $M10 \times 35$ mm (pos. 14).
8. Fix tow-ball (pos. 2) with socket plate (pos. 3) using bolts  $M12 \times 75$ mm (pos. 11).
9. Assemble a cover plate and a bumper (cut out its fragment - see fig. 3 and 4).
10. Tighten all bolts according to the torque shown in the table.
11. Connect electric wires of 7-poles socket according to the instruction of the car. (Recommend to make at authorized service station).
12. Supplement the paint coating damaged during assembly.

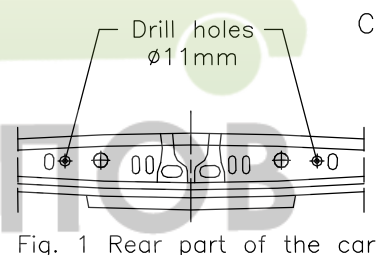

Fig. 1 Rear part of the car

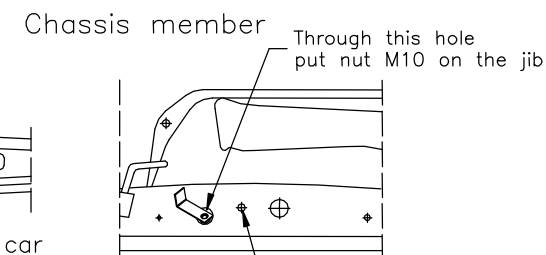

Fig. 2

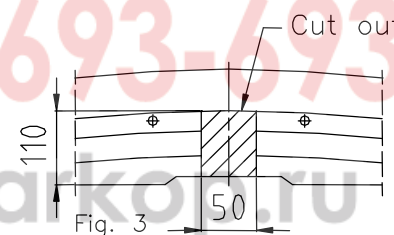

Fig. 3

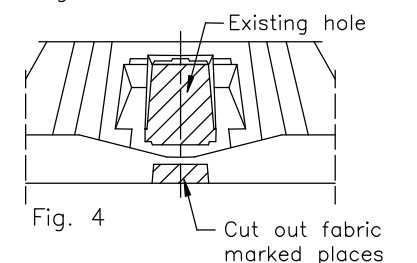

Fig. 4

Torque settings for nuts and bolts (8,8):			
<b>M 8 - 25 Nm</b>	<b>M 10 - 55 Nm</b>	<b>M 12 - 85 Nm</b>	<b>M 14 - 135 Nm</b>











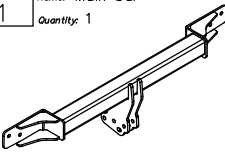

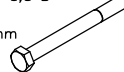

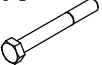







### NOTE

After install the towing hitch you should get adequate note in registration book (at authorised service station).The car should be equipped with:

- Indicators
- Tow mirrors

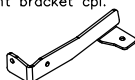
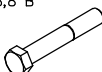
After 1000km of exploitation check all bolts and nuts. The ball of towing hitch must be always kept clear and conserve with a grease.

## Towing hitch accessories:

Pos. 1 Name: Main bar Quantity: 1 	Pos. 6 Name: Middle bracket cpl. Quantity: 1 	Pos. 12 Name: Bolt 8,8 B Quantity: 2 Dim.: M10x120mm 	Pos. 18 Name: Nut 8 B Quantity: 2 Dim.: M12 
	Pos. 7 Name: Fish-plate Quantity: 1 	Pos. 13 Name: Bolt 8,8 B Quantity: 2 Dim.: M10x90mm 	Pos. 19 Name: Nut 8 B Quantity: 6 Dim.: M10 
Pos. 2 Name: Tow ball Quantity: 1 	Pos. 8 Name: Jib with the nut Quantity: 2 	Pos. 14 Name: Bolt 8,8 B Quantity: 4 Dim.: M10x35mm 	Pos. 20 Name: Plain washer Quantity: 2 Dim.: Ø 13 mm 
Pos. 3 Name: Socket plate Quantity: 1 	Pos. 9 Name: Distance sleeve Quantity: 2 Dim.: Ø25xØ13mm L=51,5mm 	Pos. 15 Name: Bolt 8,8 B Quantity: 2 Dim.: M10x30mm 	Pos. 21 Name: Plain washer Quantity: 10 Dim.: Ø 10,5 mm 
Pos. 4 Name: Left bracket cpl. Quantity: 1 	Pos. 10 Name: Distance sleeve Quantity: 2 Dim.: Ø17,2x2,35mm L=85mm 	Pos. 16 Name: Washer Quantity: 2 Dim.: Ø35xØ12,5x3mm lub Ø42xØ12,5x3mm 	Pos. 22 Name: Spring washer Quantity: 2 Dim.: Ø 12,2 mm 
Pos. 5 Name: Right bracket cpl. Quantity: 1 	Pos. 11 Name: Bolt 8,8 B Quantity: 2 Dim.: M12x75mm 	Pos. 17 Name: Washer Quantity: 2 Dim.: Ø29xØ12,5x3mm 	Pos. 23 Name: Spring washer Quantity: 10 Dim.: Ø 10,2 mm 
			Pos. 24 Name: Ball cover Quantity: 1 



**PPUH AUTO-HAK S.J.**

Produkcja Zaczepów Kulowych  
Henryk & Zbigniew Nejman  
76-200 SŁUPSK ul. Słoneczna 16K  
tel/fax (059) 8-414-414; 8-414-413  
E-mail: [office@autohak.com.pl](mailto:office@autohak.com.pl)  
[www.autohak.com.pl](http://www.autohak.com.pl)

## Towing hitch (without electrical set)

Class: **A50-X** Cat. no. **Y28**

Designed for:

Manufacturer: **HONDA**

Model: **ACCORD**

Type: **TOURER/WAGON Estate**

produced since 12.2002 till 2008

Technical data:

**D-value: 8,56 kN**

maximum trailer weight: **1500 kg**

maximum vertical cup load: **75 kg**

**Approval number acc. to regulations EKG/ONZ 55.01: E20-55R-01 1048**

## Foreword

This towing hitch is designed according to rules of safety traffic regulations. The towing hitch is a safety component and can be install only by qualified personnel. Any alteration or conversion of the towing hitch is prohibited and would lead to cancellation of design certification. Remove insulating compound and underseal from vehicle (if present) in the area of the matting surfaces of the towing hitch. The vehicle manufacturer's specifications regarding trailer load and max. vertical cup load are decisive for driving whereat values for the towing hitch cannot be exceeded.

*D-value formula:*

$$\frac{\text{Max trailer weight [kg]} \times \text{Max vehicle weight [kg]}}{\text{Max trailer weight [kg]} + \text{Max vehicle weight [kg]}} \times \frac{9,81}{1000} = D \text{ [kN]}$$